

# SUGAR GLIDER

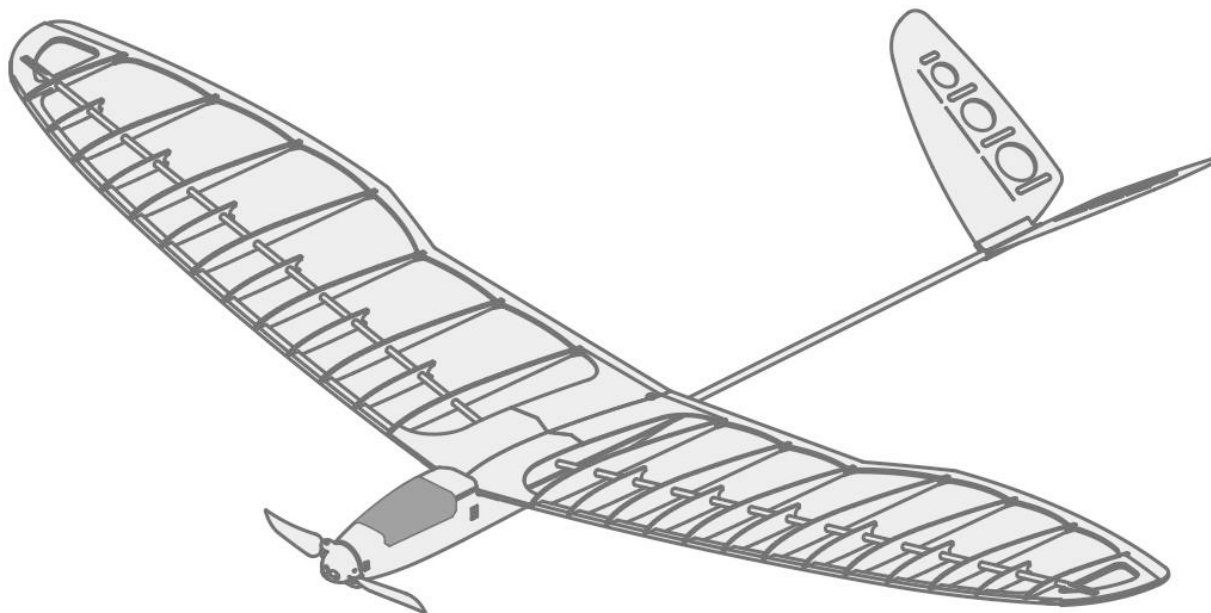

## Specifications

@sugarglider\_f5k

- Wing span : 1m
- Wing area : 15.6dm<sup>2</sup>
- Length : 680mm
- Flying weight from : 130g
- Wing loading : 8.3g/dm
- Aspect ratio : 6.4
- Wing airfoil : AG37 mod
- Dihedral angle : 10°
- Centre of Gravity : 67±2mm from wing leading edge
- Controls : Ruddervator or Rudder, Elevator

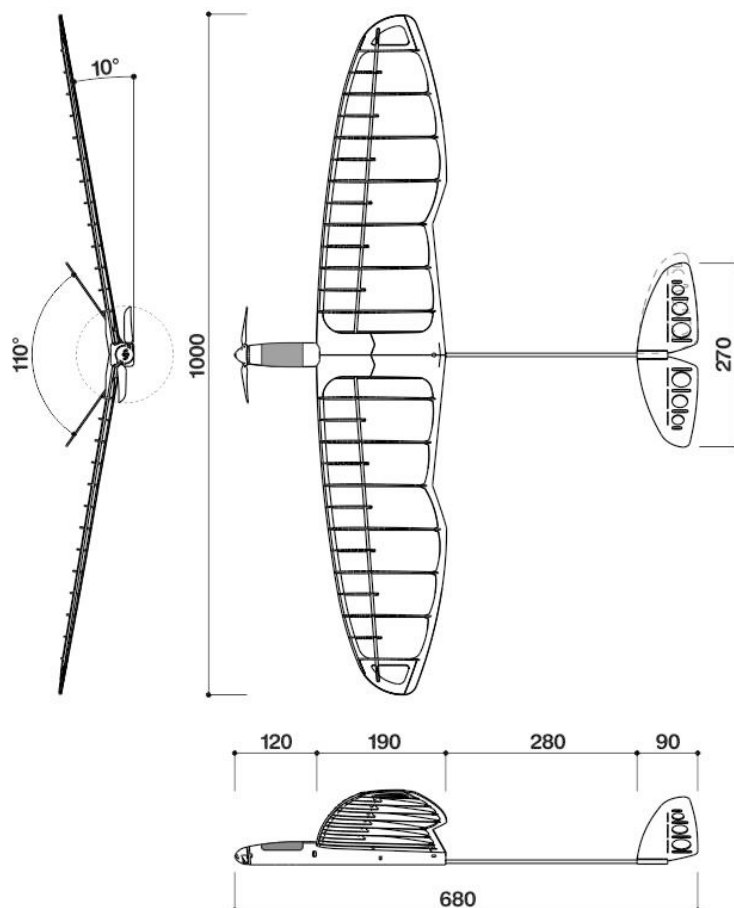

**A. Balsa - 1mm**

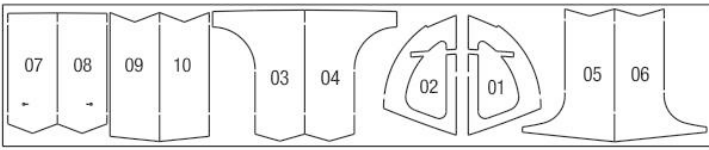

**B. Balsa - 1.5mm**

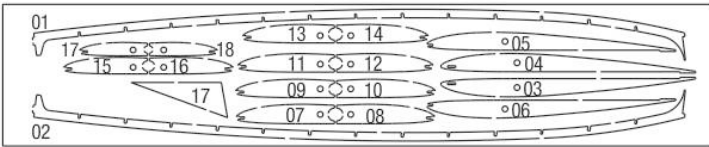

**C. Balsa - 2mm**

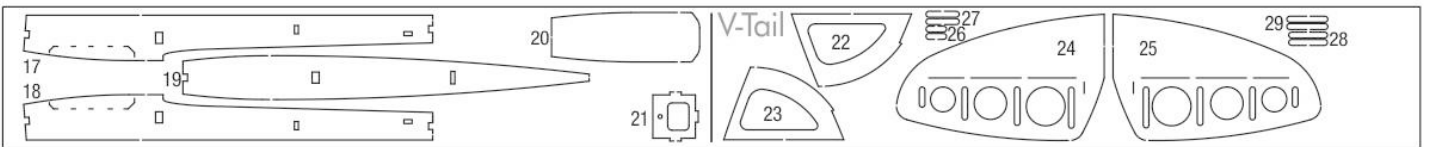
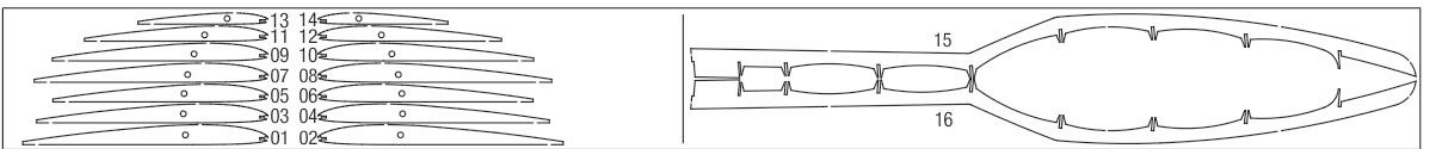

**D. Balsa - 3mm**

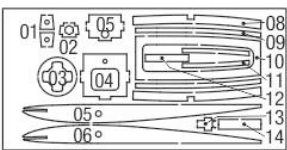

**E. Plywood - 3mm**

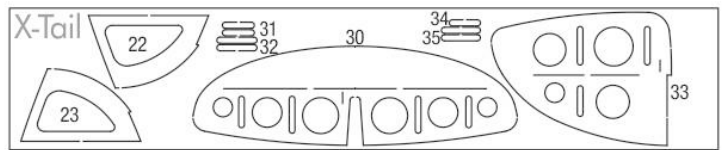

**F. Carbon Pipe -  $\varnothing$ 5x425mm**



**G. Carbon Pipe -  $\varnothing$ 4x490mm**



**H. Carbon Rod -  $\varnothing$ 3x35mm**



**I. Wooden Rod -  $\varnothing$ 3x483mm**



**J. V(X)-Tail Mount**



**K. Control Horn**



**L. Bolt / Nut - M3**



**M. Pull String**



**N. Crimp Sleeve**



**O. Torsion Spring**



**P. Carbon sheet - 15x15x0.3mm**



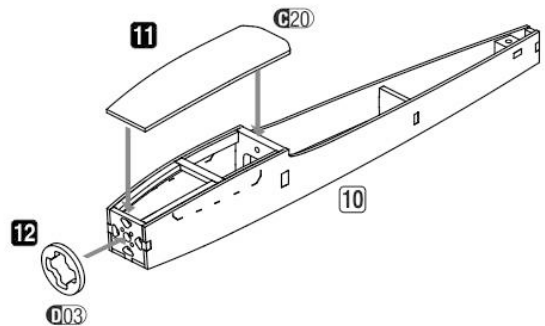
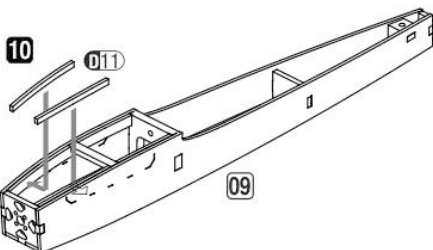
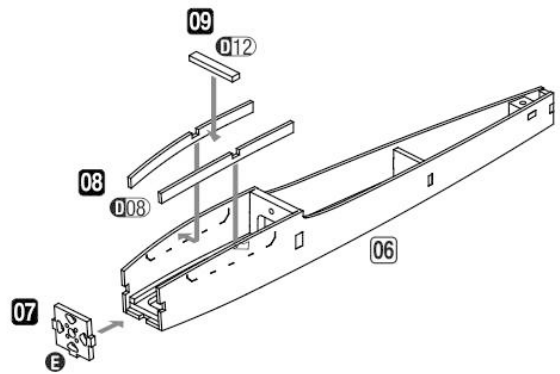
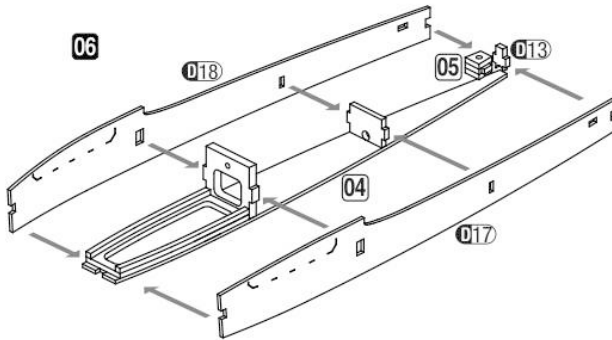
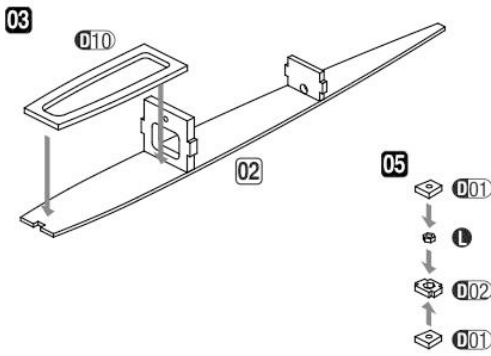
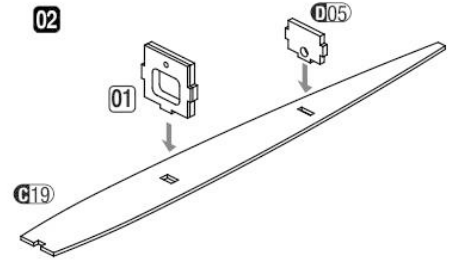
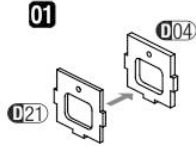
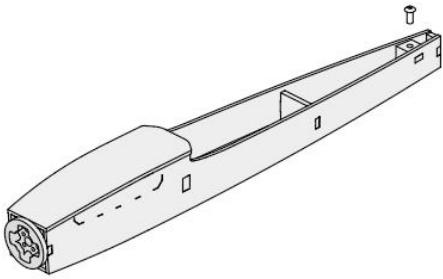

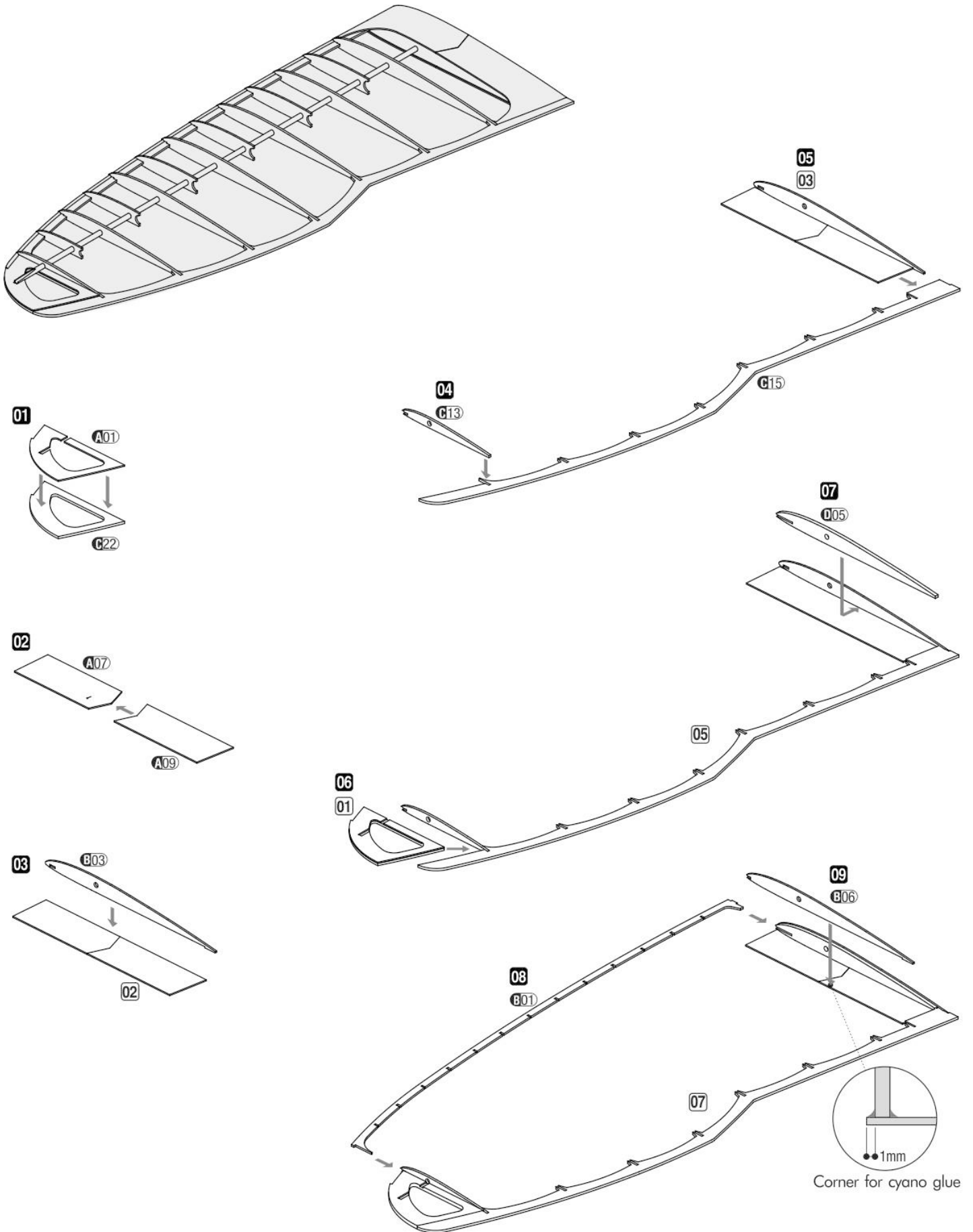

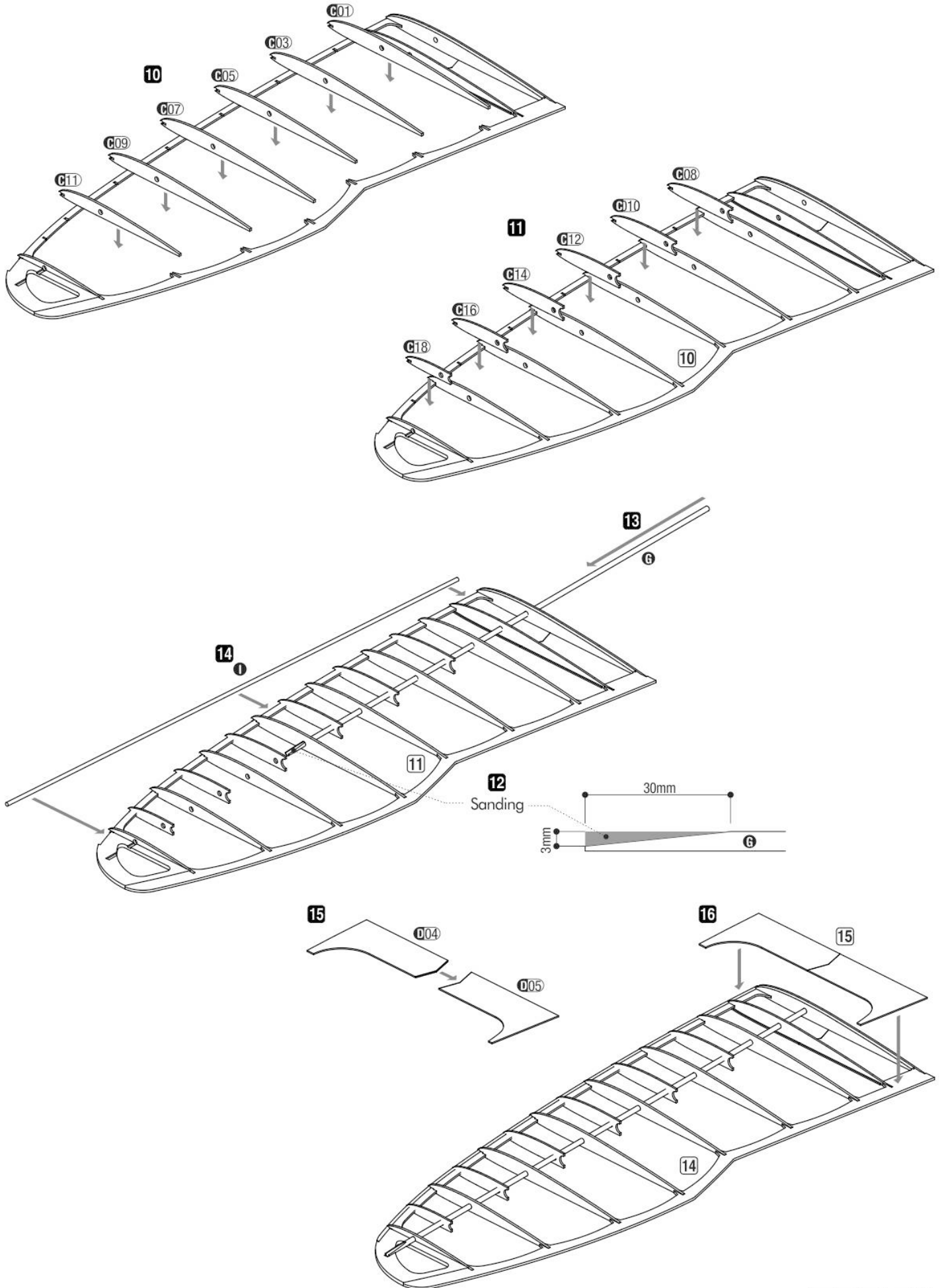

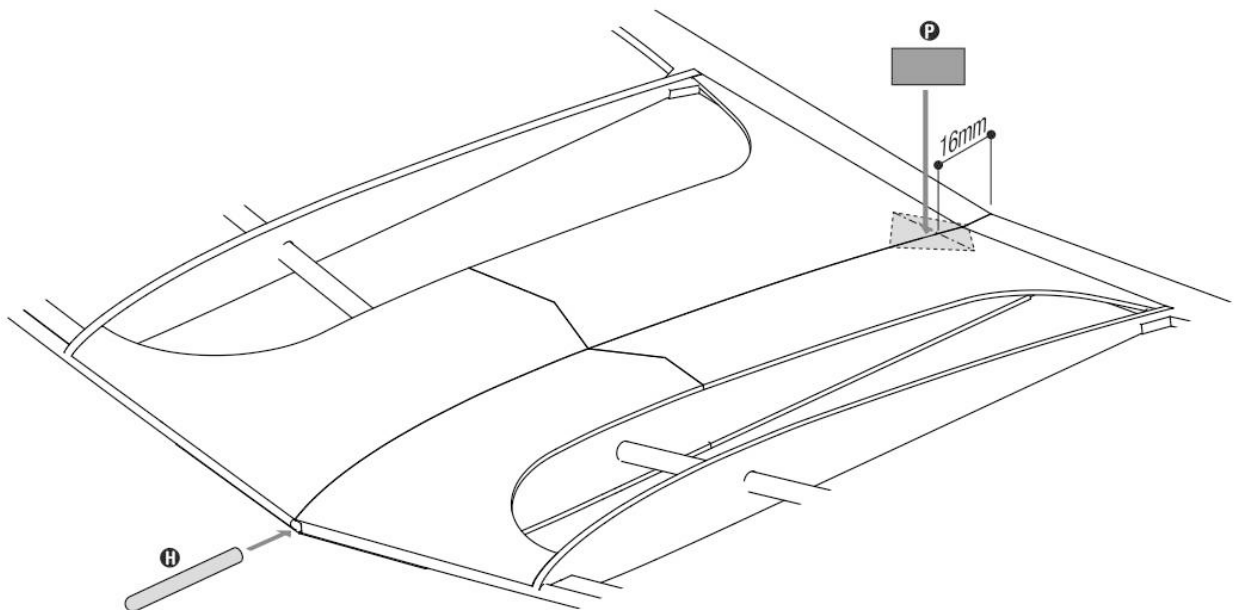
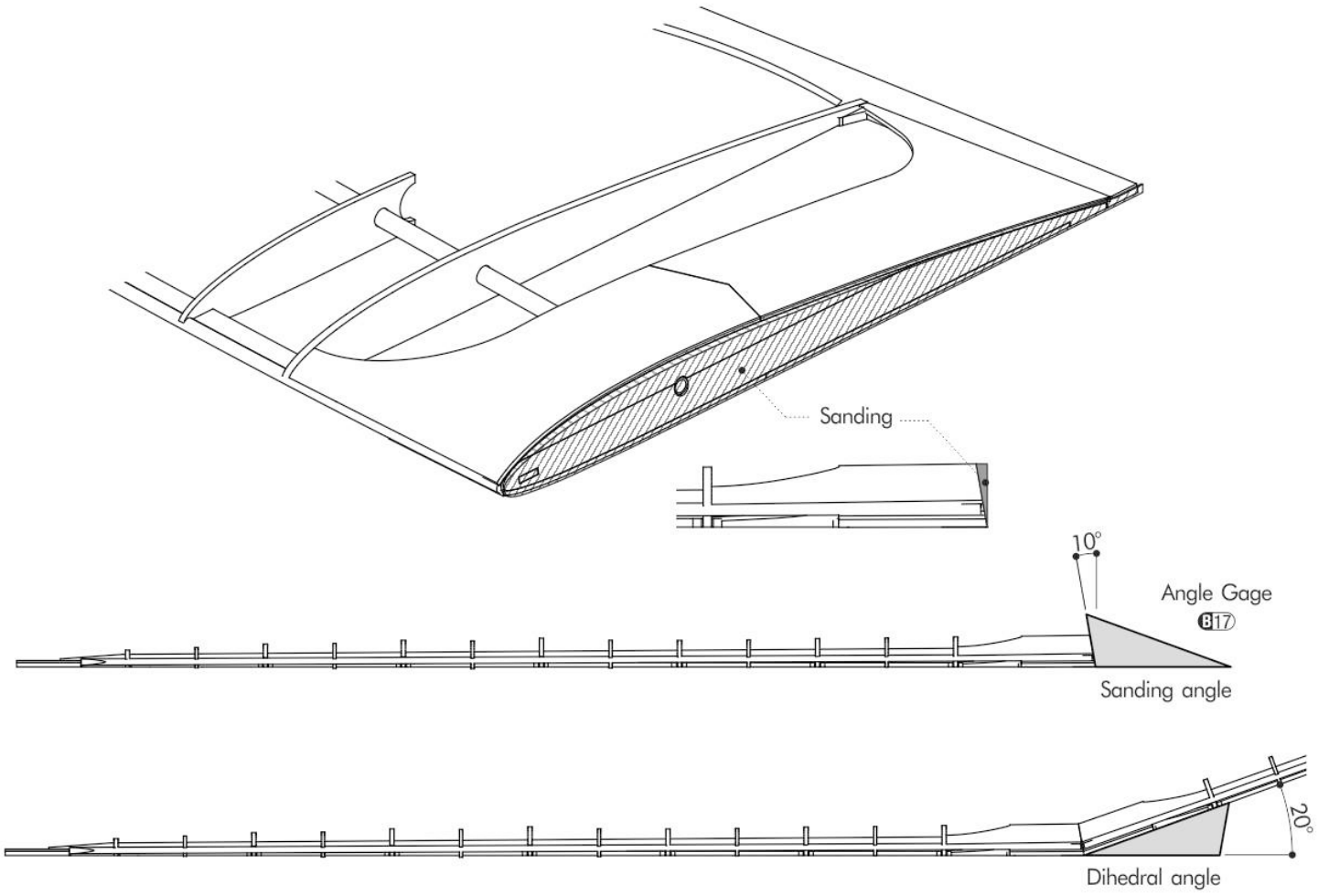

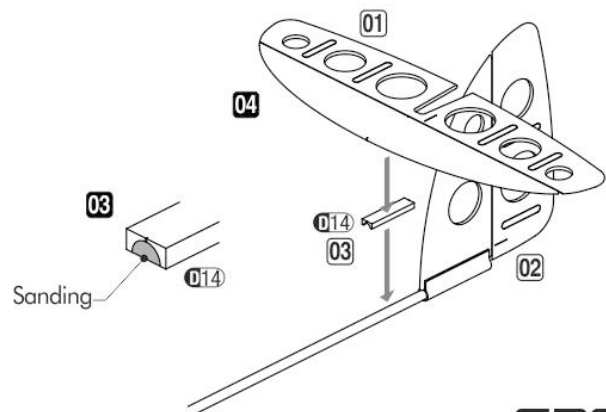
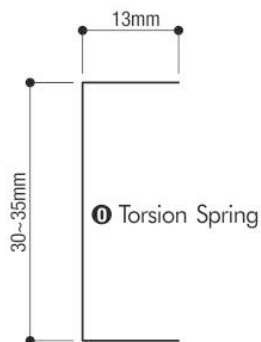
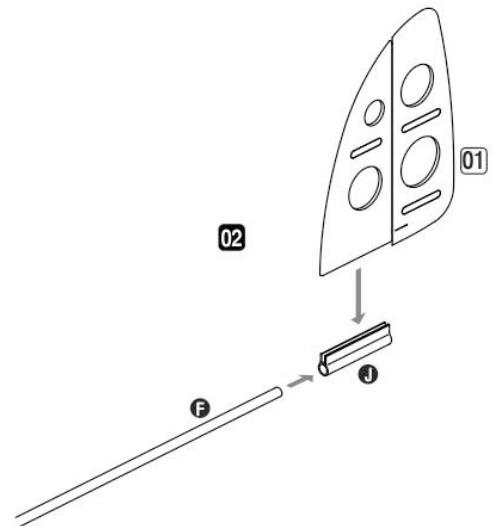
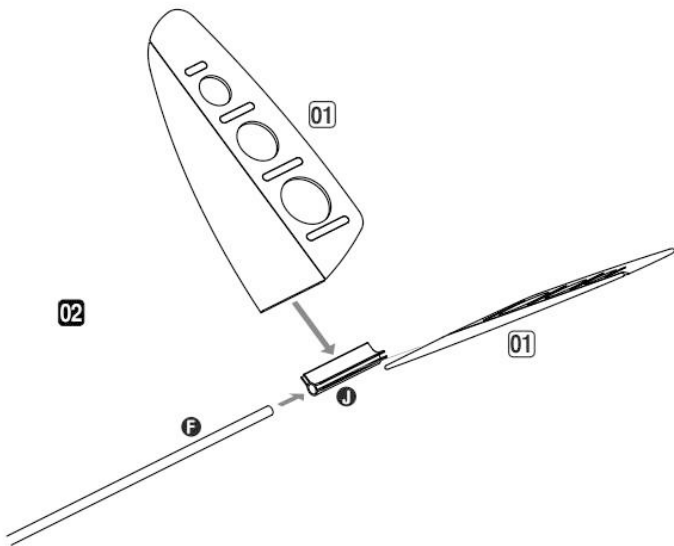
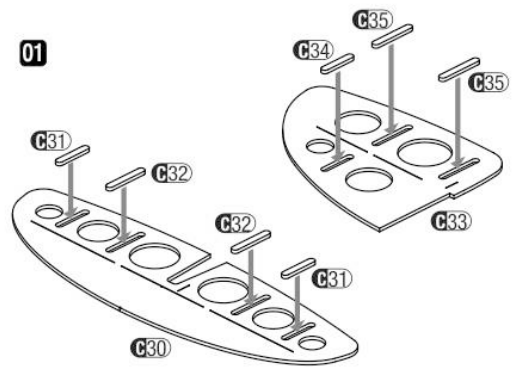
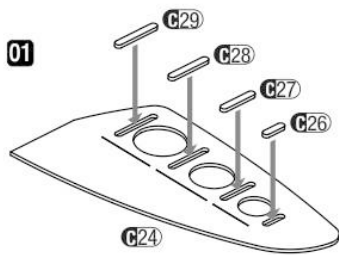
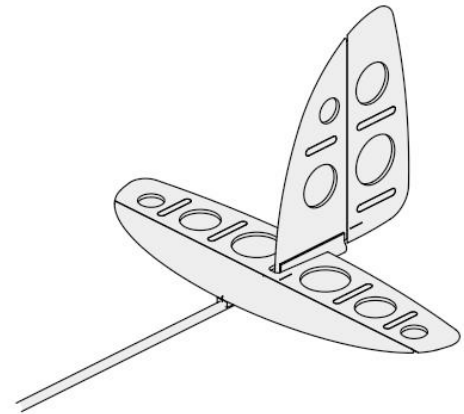
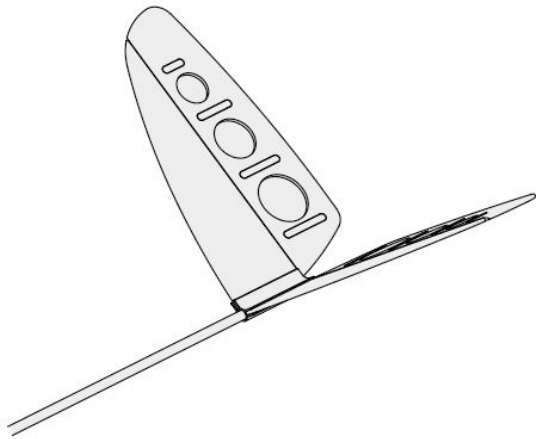



Hello,

Sugar Glider's want to be the closest and most comfortable glider to you.

Please make it calmly with your sincerity and effort.

You will then be rewarded with that much flight performance.

Thank you very much.

✉ [grafx@naver.com](mailto:grafx@naver.com)

📷 [grafx\\_lee](#)

▶ [grafxlee](#)