

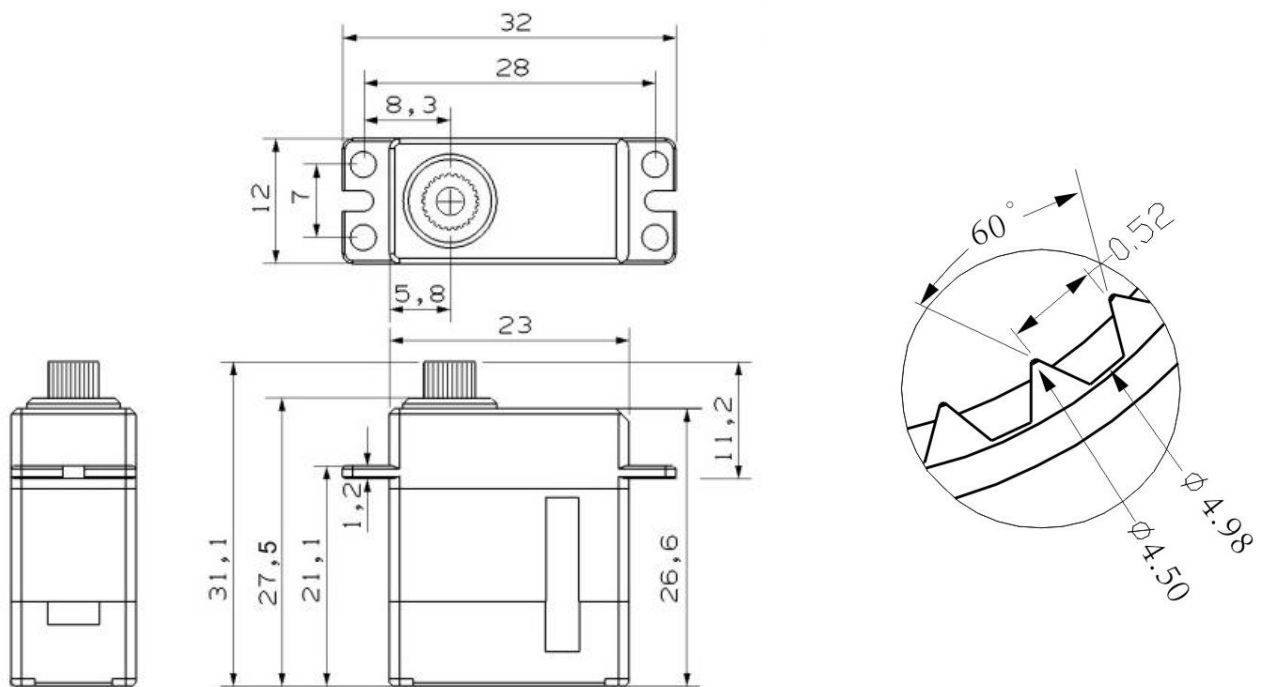

# X12-508

## Technical Specification





## Operating Data

	<b>X12-508</b>
<b>Operation Voltage(rated)</b>	DC7.4V
<b>Operation Voltage Range</b>	DC4.8V-8.4V
<b>Torque</b>	4.2Kg.cm@6.0V
	5.2Kg.cm@7.4V
	6.20Kg.cm@8.4V
<b>Speed</b>	0.09sec/60 °@6.0V
	0.08sec/60 °@7.4V
	0.07sec/60 °@8.4V
<b>Travel Angle</b>	± 50° when 1000-2000us
<b>Operating Temperature Range</b>	-20℃ ·····+65℃



# Performance

**X12-508**

**@6.0V**

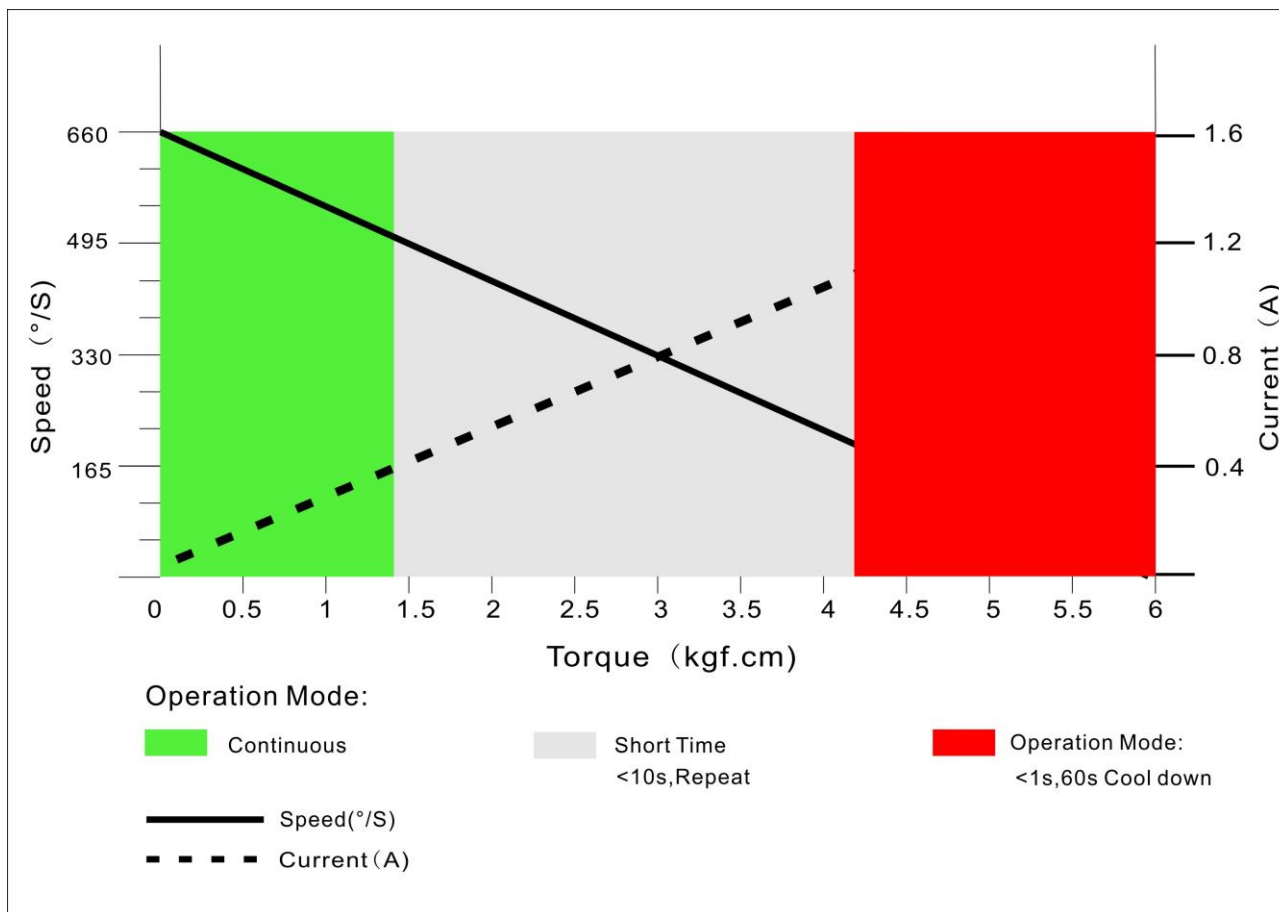



## PWM Command Signal

PWM	X12-508
Signal Voltage	TTL-Level: HIGH:min.3.3V,max.5.0V TTL-Level: Low:min.0.0V,max.1.5V
Pulse Lengths	900-2100us
Pulse Lengths for Position $-50^{\circ}$ /center/ $+50^{\circ}$	1000us/1500us/2000us
Resolution	<2us

### Materials and protective features

Case Material	Aluminum Alloy
Salt Water Resistance	
EMI/RFI Shielding	
Motor Type	Coreless
Gear Set Material	Hardened Steel
Position Sensor	Potionmeter
Position Feedback	Optional
Shielded Connecting Cable	26AWG

### Dimensions

Case Dimensions	23*12*27.5mm
Weight	20g