

AerobTec

Telemetry Converter

Spektrum / Hitec Telemetry



Manufacturer:
AerobTec, s.r.o.
Ilkovičova 3
841 04 Bratislava

www.aerobtec.com
info@aerobtec.com

Table of Contents

Specifications.....	3
Introduction.....	3
Hardware description.....	3
Connectors of the Telemetry Converter.....	3
The power supply of the Telemetry Converter.....	4
The Telemetry Converter and the Altis Device.....	4
The Telemetry Converter and Spektrum.....	5
The receiver.....	5
The connection for measuring of two voltages.....	6
The transmitter.....	6
The Telemetry Converter and Hitec.....	7
The receiver.....	8
The connection for measuring of two voltages.....	8
The transmitter.....	9
Warning.....	10
Correct disposal of this product.....	11
Notes.....	11
Revision History.....	11

1. Specifications

- ▲ Dimensions: 18 x 11 x 5mm
- ▲ Weight: 1.2g
- ▲ Power supply range: 4 – 8.4V
- ▲ Telemetry support for Spektrum X-Bus, Hitec Data Port

2. Introduction

The AerobTec Telemetry Converter is an extension of Altis Devices: Altis v4, Altis v4+, Altis Micro, Altis GPS. It enriches Altis Devices by new telemetric protocols of Spektrum and Hitec.

The AerobTec Telemetry Converter selects only the essential from the wide range of information obtained during the flight of the aircraft. The essential information for Altis altimeters is the altitude, vario, temperature and voltage. The Altis GPS, however, works also with ground speed, time, date and information associated with the GPS coordinates.

3. Hardware description

Connectors of the Telemetry Converter

The Telemetry Converter has 2 connectors. They are shown in Fig. 1.

- COM – Molex connector for the connection with an Altis Device
- RX – Molex connector for the connection with telemetry equipped receivers

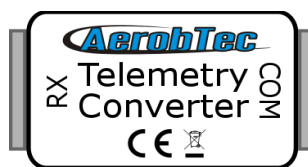

Fig. 1: Connectors of the telemetry converter

Wire color	Signal
brown	Ground
red	Positive power supply
orange	Telemetry signal

Table 1: Colors of the COM port connector wires

The power supply of the Telemetry Converter

Telemetry converter is supplied from the COM connector (polarity according to Table 1) side and its power supply is not passed to the RX connector therefore the receiver needs a separate power supply.

4. The Telemetry Converter and the Altis Device

Telemetry Converter is connected to the COM connector of the Altis Device with a pair of JR/Molex cables. In order to activate the Spektrum/Hitec telemetry, it is necessary to set the Spektrum/Hitec telemetry in the Altis Device through the Altis Flight Manager software as shown in the Fig. 2.

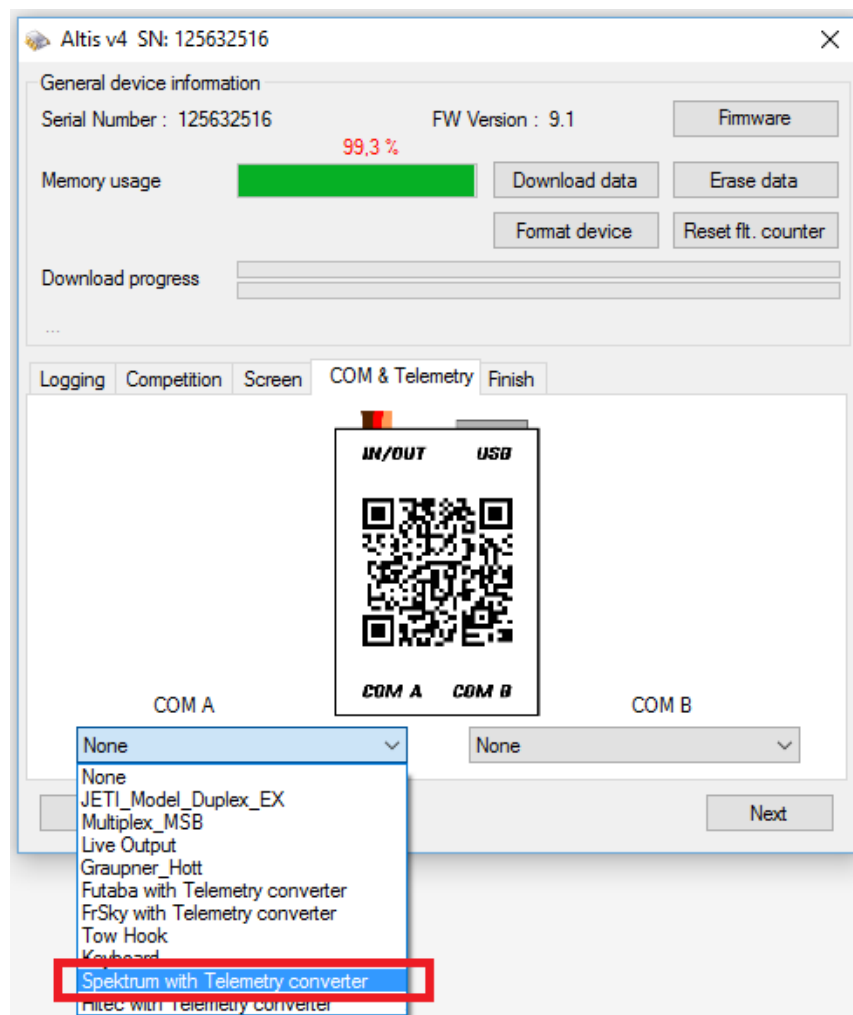

Fig. 2: Example setting in Altis Flight Manager (Altis v4 -> COM A)

5. The Telemetry Converter and Spektrum

The Telemetry Converter communicates with the Spektrum device using Spektrum X-Bus. In the case of Spektrum telemetry, Rx connector is connected first to the TM1000 module and this module is connected to the receiver.

The receiver

First of all, it is necessary to find the appropriate connector on the TM 1000 telemetry module (the one with an X-Bus marking). In order to connect the Telemetry Converter with the receiver use the Molex / 4pin JST ZHR-4 cable

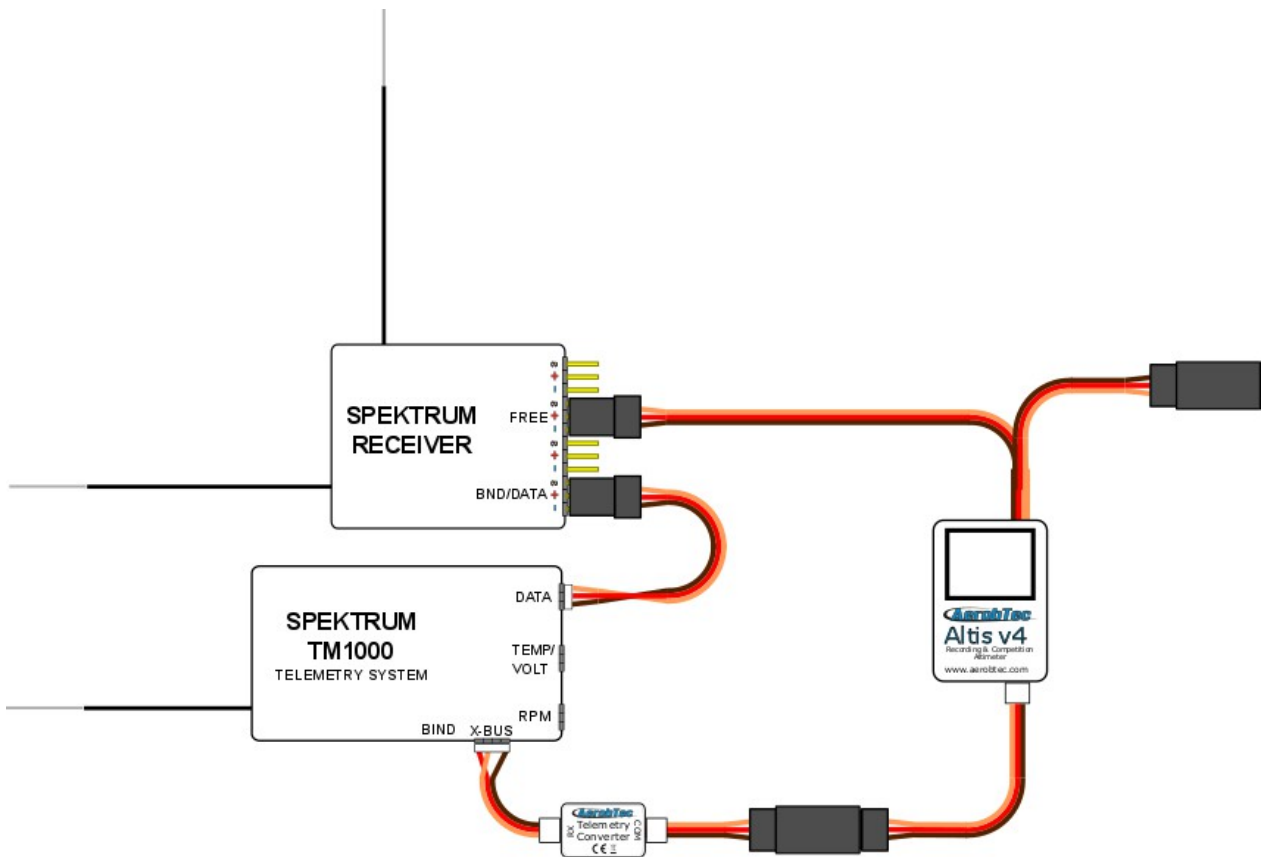

Fig. 3: Connection of the Telemetry Converter with Spektrum

The connection for measuring of two voltages

Altis altimeter or Altis GPS with Telemetry Converter (Hitec/Spektrum) can be connected so that it displays two voltages. Each Telemetry module TM1000 and Altis devices measure their power supply voltage and each of them can be displayed if you use the connection according to Fig. 4. Note not to exceed the power supply ranges of the devices.

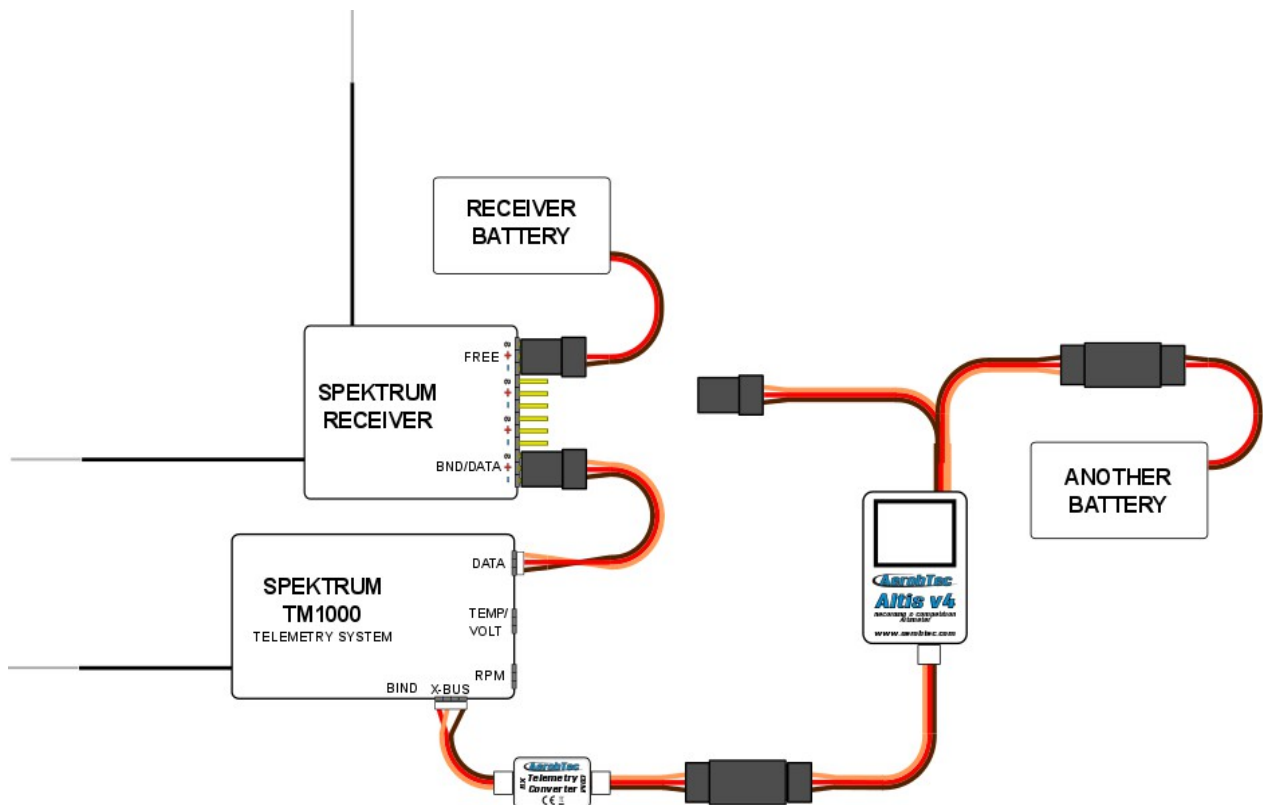

Fig. 4: Connection for measuring of two voltages

The transmitter

The telemetric information from the Altis Device is transformed via the Telemetry Converter and TM1000 module and is displayed on the Spektrum transmitter. In order to set the telemetric parameters, it is necessary to follow the user manual of your transmitter which can be downloaded at <http://www.spektrumrc.com>.

Spektrum terms for individual telemetric parameters are listed in Table 2 (for altimeters) and Table 3 (for GPS).

Parameter	Transmitter screen	Spektrum term	Unit
Relative altitude*	Vario	Altitude	[m]
Vario	Vario	-	[m/s]
Temperature	Flight Pack Capacity	Temp	[°C]
Voltage	Rx Pack Capacity	Volts	[V]

Table 2: Spektrum telemetric terms in altimeters

Parameter	Transmitter screen	Spektrum term	Unit
Speed	GPS	Speed	[km/h]
Absolute/relative* altitude**	GPS	Alt	[m]
Latitude	GPS	Lat	[°]
Longitude	GPS	Lon	[°]
Time	GPS	Time	HH:MM:SS
Count of satellites	GPS	Sats	[]
Temperature	Flight Pack Capacity	Temp	[°C]
Voltage	Rx Pack Capacity	Volts	[V]
Vario	Vario	-	[m/s]

Table 3: Spektrum telemetric terms in GPS

Depending on the model of the transmitter, the Spektrum terms may vary. (Tested for DX6 model). Parameter Heading is displaying value 999.9°, because this parameter is not measured with Altis GPS.

Temperature under zero is indicated by dashes, over the value of temperature.

It is not recommended to use Altis altimeters or Altis GPS with other sensors providing the same telemetric parameters. It is also not recommended to use Altis altimeter with Altis GPS on the same X-Bus.

*These parameters are relative, therefore their reference point must be set by restarting the transmitter or by resetting the telemetry on the transmitter.

**Depending on settings of Transmitter (MSL-Absolute altitude, AGL-Relative altitude)

6. The Telemetry Converter and Hitec

The Telemetry Converter communicates with the Hitec device through a Hitec Data Port. In the case of Hitec telemetry, only the TM1000 telemetry module may be connected to the RX connector.

The receiver

First of all, it is necessary to find the appropriate connector on the receiver (the one with a DATA marking). In order to connect the Telemetry Converter with the receiver, a JR / Molex cable must be used.

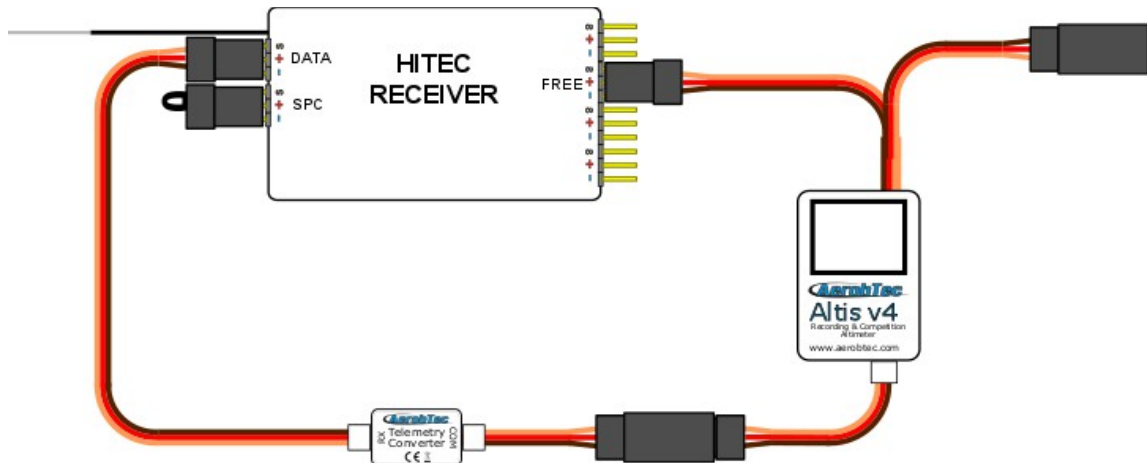

Fig. 5: Connection Telemetry Converter with Hitec receiver

The connection for measuring of two voltages

Altis altimeter or Altis GPS with Telemetry Converter (Hitec/Spektrum) can be connected so that it displays two voltages. Each Hitec receiver and Altis devices measure their power supply voltage and each of them can be displayed if you use the connection according to Fig. 4. Note not to exceed the power supply ranges of the devices.

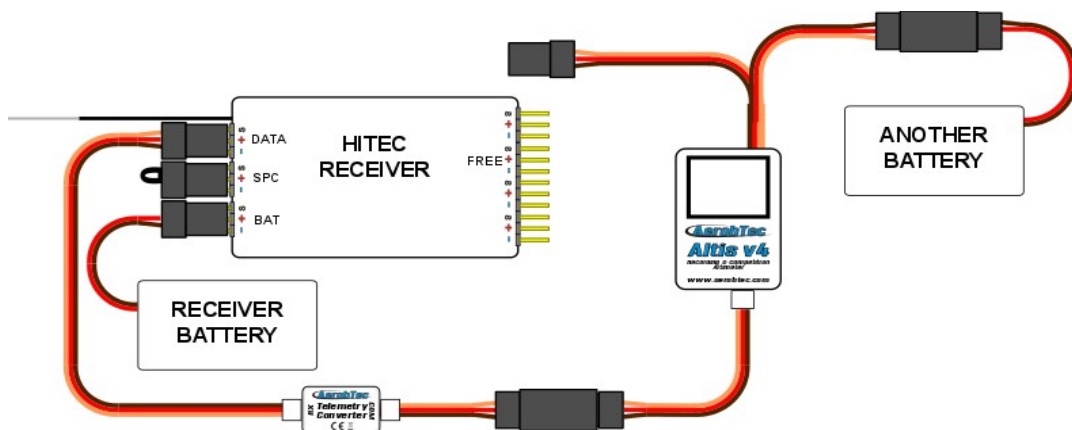

Fig. 6: The connection for measuring of two voltages

The transmitter

The telemetric information from the Altis Device is transformed via the Telemetry Converter and displayed on the Hitec transmitter. In order to set the telemetric parameters, it is necessary to follow the user manual of your transmitter which can be downloaded at <http://www.hiteccrd.com>

Hitec terms for individual telemetric parameters are listed in Table 4 (for altimeters) and in Table 5 (for GPS).

Parameter	Hitec term	Unit
Relative altitude*	VARIO ALT.	[m]
Temperature	Temp-1	[°C]
Vario	Temp-3	[m/s]
Vario(1/10 th of Vario)	Temp-4	[m/s]
Voltage	Voltage	[V]

Table 4: Hitec telemetric terms in altimeters

Parameter	Hitec term	Unit
Date	-	MM/DD/RR
Time	-	HH:MM:SS
Latitude	Latitude	SS°MM'SS.SS"
Longitude	Longitude	SS°MM'SS.SS"
Absolute/relative* altitude**	Altitude	[m]
Speed	Speed/GPS SPEED	[km/h]
Temperature	Temp-1	[°C]
Vario	Temp-3	[m/s]
Vario(1/10 th of Vario)	Temp-4	[m/s]
Voltage	Voltage	[V]

Table 5: Hitec telemetric terms in GPS

Range of Vario is from -40 m/s to +215 m/s. Range is given by the manufacturer Hitec(value out of range is indicated by zero).

Depending on the model of the transmitter, the Hitec terms may vary. (Tested for Aurora 9 model).

Telemetry convertor is working as Hitec Sensor Station.

*These parameters are relative, therefore their reference point must be set by restarting the transmitter or by resetting the telemetry on the transmitter.

**Depending on settings of Transmitter (MSL-Absolute altitude, AGL-Relative altitude)

The number of connected satellites with Altis GPS is displayed on the Hitec transmitter by count of segments on indicator next to icon of satellite.

Amount of satellites	Count of segments
1-2	1
3-4	2
5-6	3
7	4
8 and more	5

Table 6: Amount of satellites displayed on the Hitec transmitter

Ascending/descending flight (Vario) is also shown at the position of the fuel-tank (4 segments on indicator).

State of flight	Count of segments	Vario[m/s]
Faster ascending flight	4	0.6 and more
Slower ascending flight	3	from 0.3 to 0.6
Remain at current altitude	2	from 0.3 to -0.3
Slower descending flight	1	from -0.3 to -0.6
Faster descending flight	0	-0.6 and less

Table 7: Ascending/descending flight displayed on the Hitec transmitter

7. Warning

Do not touch the Telemetry Converter device to a metal surface, as this might lead to shorting of the power supply and RC system may fail.

Use correct orientation of power supply.

Do not put the Telemetry Converter in water, fuel or other liquids!

Before flying with the Telemetry Converter always perform a range check!

Do not swap COM port and RX port connection.

8. Correct disposal of this product



This product should not be disposed with other household wastes at the end of its working life. To prevent possible harm to the environment or human health from uncontrolled waste disposal, please separate this from other types of wastes and recycle it responsibly to promote the sustainable reuse of material resources. Household Users should contact either the retailer where they purchased this product, or their local government of fice, for details of where and how they can take this item for environmentally safe recycling. Business users should contact their supplier and check the terms and conditions of the purchase contract. This product should not be mixed with other commercial wastes for disposal.

9. Notes

- ^ This manual is based on Altis Flight Manager version 4.1
- ^ Note – Telemetry Converter was developed using Atollic TrueSTUDIO®

10. Revision History

Rev. 1.0. (February 2016)

- Initial release